



Similar to figure

Data sheet

Hydraulic data

Maximum operating pressure P_N	10 bar
Min. fluid temperature T_{min}	-20 °C
Max. fluid temperature T_{max}	130 °C

Materials

Pump housing	Grey cast iron
Impeller	PP-LGF50
Shaft	Stainless steel
Bearing	Carbon-graphite

Motor data

Mains connection	1~230 V, 50 Hz
Rated current I_N	3.94 A
Max. speed n_{max}	2800 1/min
Power consumption $P_1(Q=max.)$ of selected impeller * number of pumps P_1	820 W
Interference emission	EN 61000-6-3
Interference immunity	EN 61000-6-2
Protection class motor	IPX4D

Installation dimensions

Pipe connection on the suction side DN_s	DN 50
Port-to-port length L_0	280 mm

Pump curves

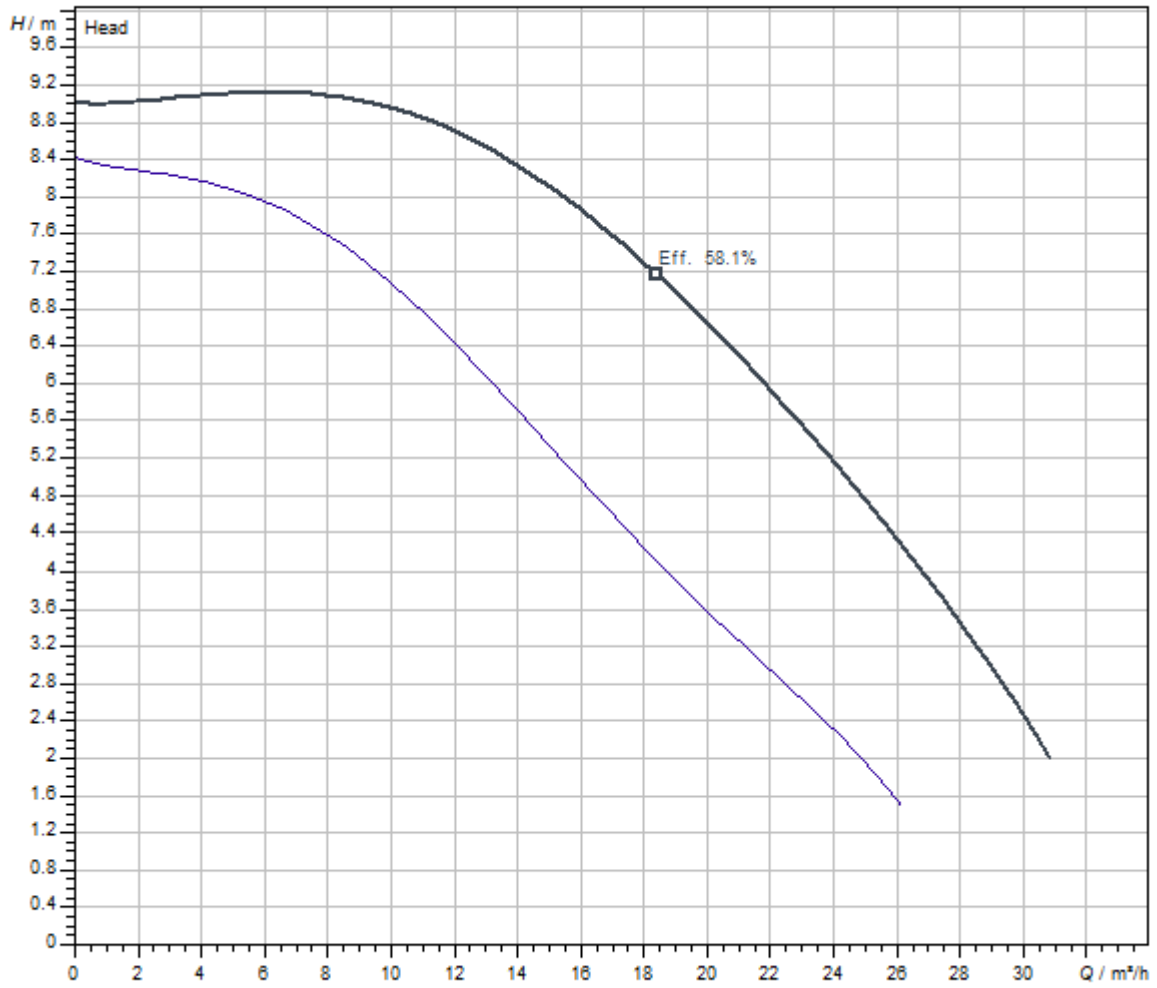

Fluid media	Water 100 %
Fluid temperature <i>T</i>	20.00 °C
speed at duty point <i>n hydr. @ OP</i>	2800 1/min

Dimensions and dimensions drawings

TOP-S

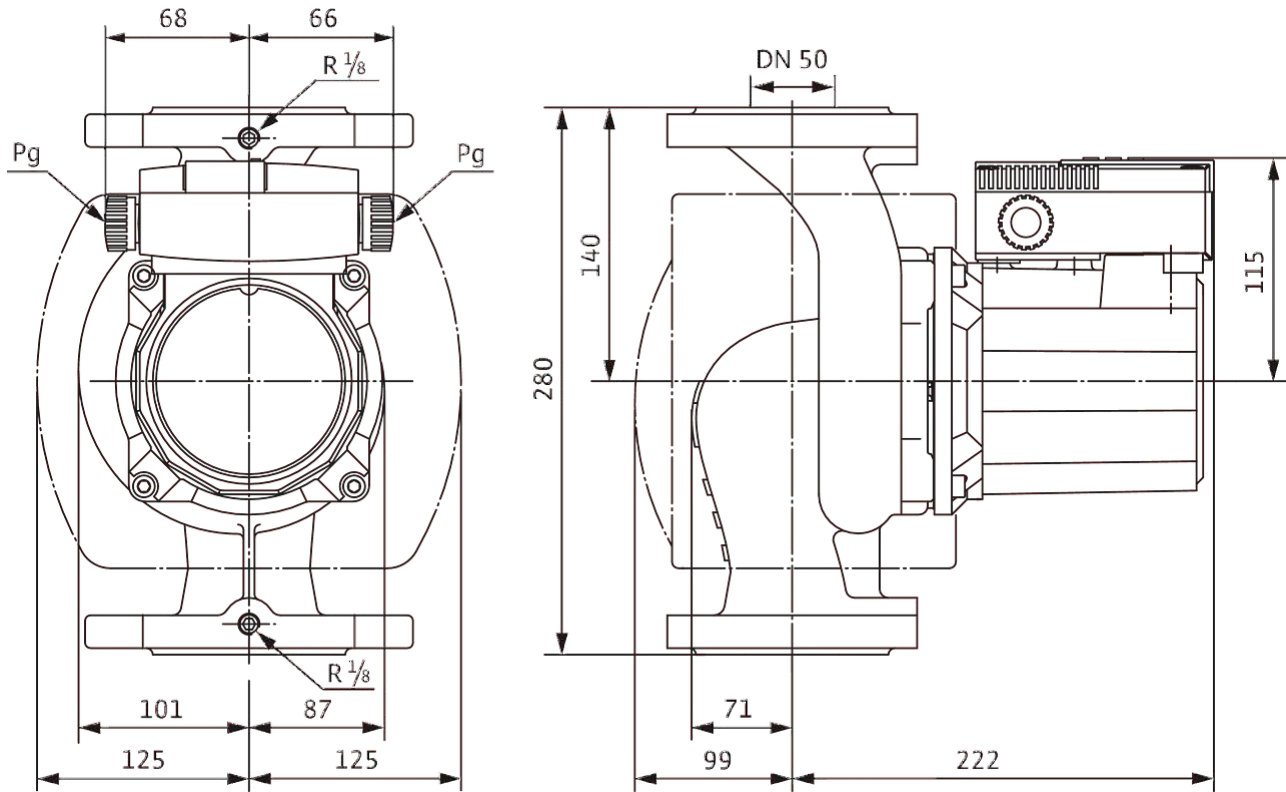

Wiring diagram

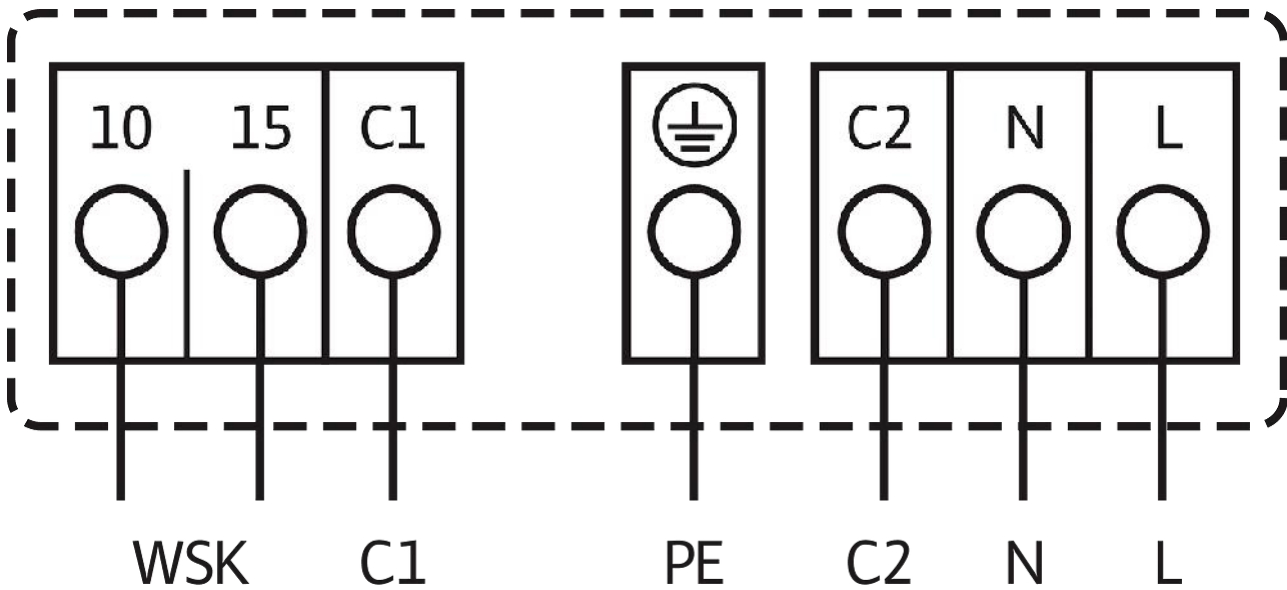

Mains connection, 1~230 V, 50 Hz

WSK = thermal winding contact

Full motor protection at all speed stages with optional tripping unit

SK 602N/SK 622N or other switchgear/control devices with WSK connection option

Triggering: External tripping at switchgear/control device

Reset: Automatic fault acknowledgement after cooling off of the motor

Automatic

Ordering information

Product data

Brand	Wilo
Product description	TOP-S 50/10 2-SPEEDS (1~230 V, PN 6/10)
Article number	2165531 
EAN number	4048482638195
Colour	green/black
Minimum order quantity	1
Date of sales availability	2016-03-01

Dimension, weight

Length with packaging	430 mm
Length <i>L</i>	280 mm
Height with packaging	290 mm
Height <i>H</i>	321 mm
Width with packaging	230 mm
Width <i>W</i>	250 mm
Gross weight, approx. <i>m</i>	19 kg
Net weight, approx. <i>m</i>	17.8 kg

Packaging

Number per layer	7
Packaging property	Transport packaging
Packaging type	Cardboard box
Pieces per pallet	28