



Data sheet

Hydraulic data

Maximum operating pressure p	1.7 bar
Discharge port	DN 65/80
Free ball passage of the hydraulics	65 mm
Impeller type	Vortex impeller
Max. immersion depth	20 m
Max. delivery head H_{\max}	15.5 m
Max. volume flow Q_{\max}	60.0 m ³ /h
Min. fluid temperature T_{\min}	3 °C
Max. fluid temperature T_{\max}	40 °C
Min. ambient temperature T_{\min}	3 °C
Max. ambient temperature T_{\max}	40 °C

Motor data

Motor Identifier	P 13.1-10/EAD1X2-T Ex 2,5kW
Mains connection	3~400 V, 50 Hz
Voltage tolerance	±10 %
Rated power P_2	2.5 kW
Power consumption $P_{1\max}$	3.20 kW
Rated current I_N	5.5 A
Starting current I	31 A
Operating mode (immersed)	S1
Operating mode (non-immersed)	S2-30 min
Rated speed n	2848 1/min
Power factor $\cos \varphi$	0.84
Activation type	Direct On Line (DOL)
Number of poles	2
Max. switching frequency t	60 1/h
Insulation class	F
Protection class motor	IP68

Cable

Connection cable length	10 m
Cable type	H07RN-F
Cable cross-section	7G1,5 mm ²
Type of connection cable	Detachable

Equipment/function

Mains plug	no
Float switch	no
Macerator	no
Explosion protection type	ATEX
Motor protection	Bimetall
Motor, leakage detection	yes
Sealing chamber, leakage detection	optional
Leakage chamber, leakage detection	no

Materials

Pump housing	Grey cast iron
Impeller	Grey cast iron
Shaft	Stainless steel
Sealing on pump side	Silicon carbide
Sealing on motor side	NBR
Gasket material	NBR
Motor housing	Grey cast iron

Installation dimensions

Inlet connection	DN 65
Outlet connection	DN 65/80

Pump curves

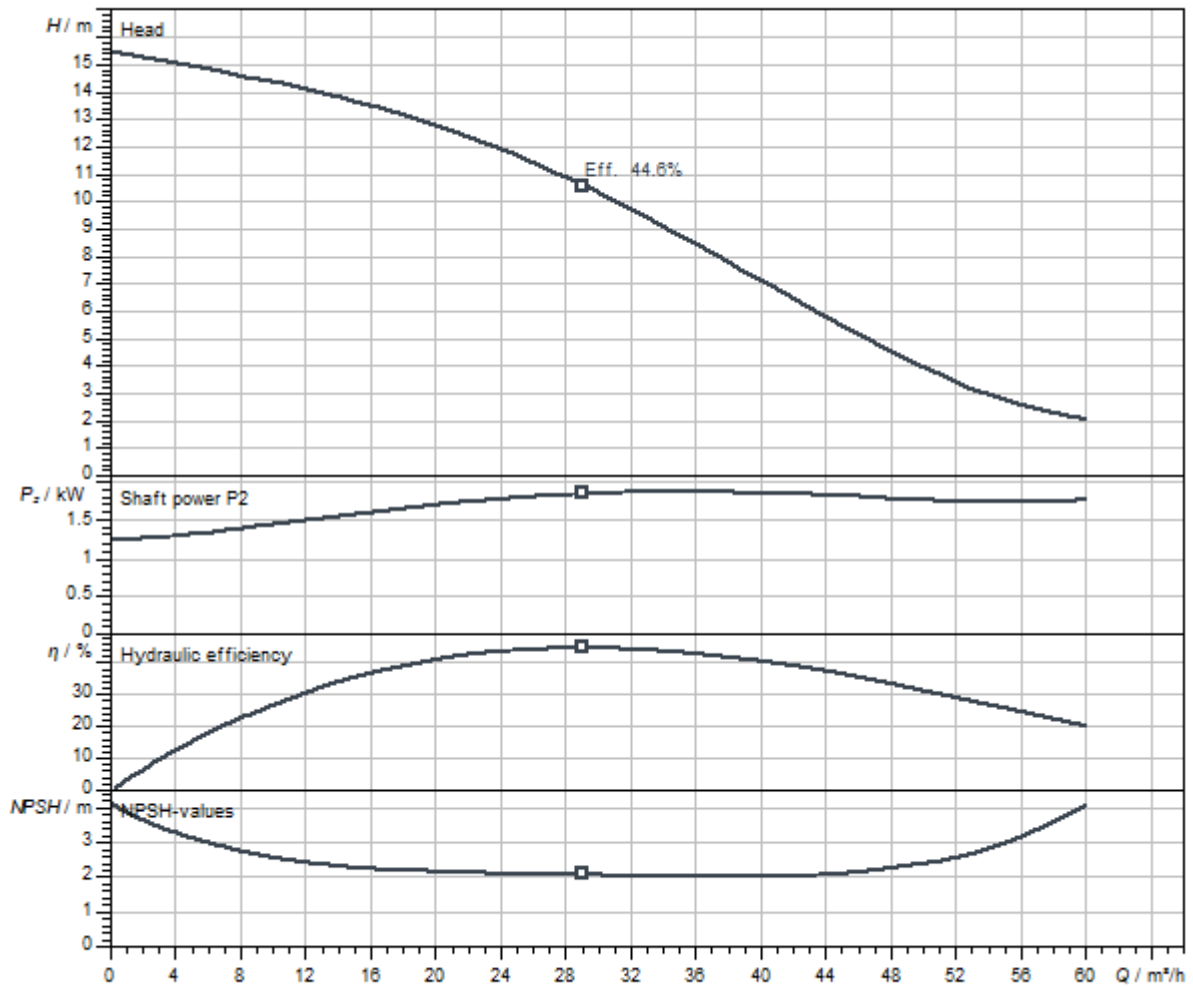

Fluid media	Water 100 %
Fluid temperature <i>T</i>	20.00 °C
speed at duty point <i>n hydr. @ OP</i>	2900 1/min
Impeller diameter <i>d imp.</i>	127 mm

Dimensions and dimensions drawings

Wilo-Rexa PRO V06-21.. - portable wet well installation

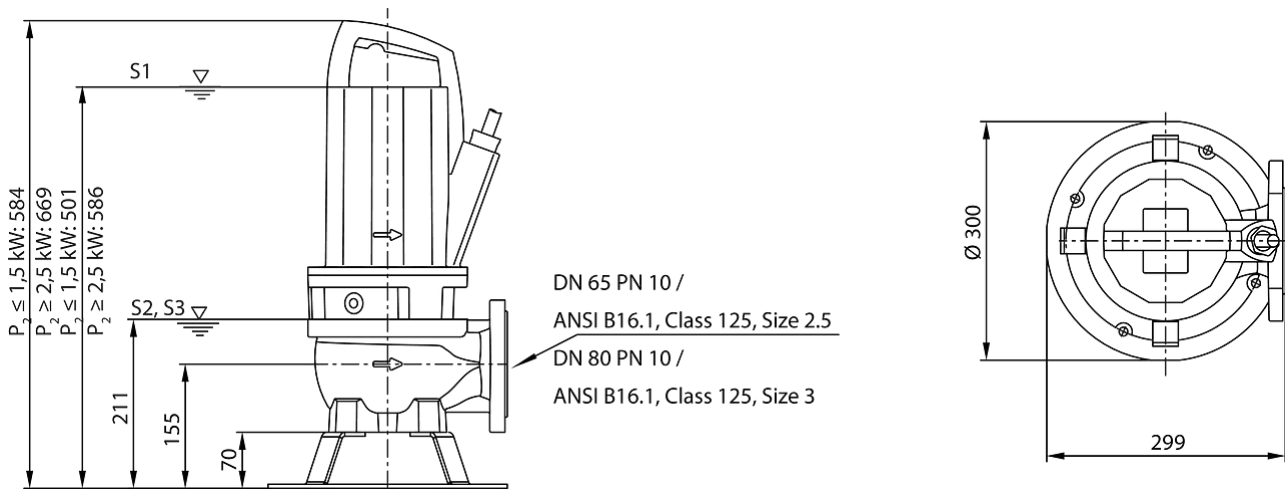

Ordering information

Product data

Brand	Wilo
Product description	Rexa PRO V06DA-216/EAD1X2-T0025-540-O
Article number	6064732
EAN number	4048482227849
Colour	Green
Minimum order quantity	1
Date of sales availability	2011-09-01

Dimension, weight

Length with packaging	400 mm
Length <i>L</i>	250 mm
Height with packaging	805 mm
Height <i>H</i>	599 mm
Width with packaging	300 mm
Width <i>W</i>	200 mm
Gross weight, approx. <i>m</i>	53 kg
Net weight, approx. <i>m</i>	51 kg

Packaging

Number per layer	1
Packaging property	Transport packaging
Packaging type	Cardboard box
Pieces per pallet	1