

ACm Centrifugal cast iron pump



Application

- Transfer of clear water or other liquids chemically and physically comparable to water
- Suitable for industrial use and water supply, overpressure for fire system, garden irrigation, air conditioning system, circulation and overpressure, etc ...

Pompe

- Special anti-rust treatment (cataphoresis) for the cast iron pump body and the lantern
- AISI 304 stainless steel shaft
- Maximum liquid temperature: +40°C
- Maximum suction height: 8 m

Moteur

- Integrated thermal protection for single-phase motors
- Insulation class: F
- Protection class: IPX4
- Maximum ambient temperature: +40°C

Identification codes

A C m 110 (L)

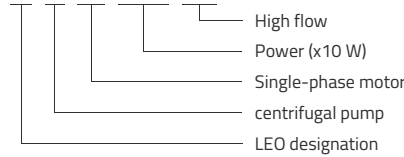

Technical data

MODEL	kW	Q (m³/h)																					
		0	0.6	0.9	1.2	1.8	2.4	3	3.6	4.2	4.5	4.8	5.4	6	6.6	7.2	7.8	8.4	9	9.6	10.8	11.7	12.6
	Q (l/min)	0	10	15	20	30	40	50	60	70	75	80	90	100	110	120	130	140	150	160	180	195	210
ACm25	0.25	17	16.5	16.2	16	15.5	14.5	13.5	12.5	10.5	9.5	8											
ACm37	0.37	23	21.5	21	21	20.5	19.5	18	17	15.5	14.5	14	12										
ACm60	0.6	27	26.5	26.2	26	25	24.5	22.5	20	17	15.5	14	10										
AC60	0.6	27	26.5	26.2	26	25	24.5	22.5	20	17	15.5	14	10										
ACm75	0.75	36	35	34	33.5	33	32	31	29	27	26	23.5	20	16									
AC75	0.75	36	35	34	33.5	33	32	31	29	27	26	23.5	20	16									
ACm110	1.1	40	39	38	38	37.5	37	36	35	33	32	31	29	26	23	20							
AC110	1.1	40	39	38	38	37.5	37	36	35	33	32	31	29	26	23	20							
ACm110L	1.1	34.5	34.3	34.2	34.1	34	33.8	33.5	33	32.5	32.3	32	31	30.5	29.5	28.5	27.5	26.5	25	23.5	20	16.5	
AC110L	1.1	34.5	34.3	34.2	34.1	34	33.8	33.5	33	32.5	32.3	32	31	30.5	29.5	28.5	27.5	26.5	25	23.5	20	16.5	
ACm150	1.5	48	47.5	47	46.5	45.5	44.5	43.5	42.5	41.5	41	41.5	39	37	34.5	31	27	22					
AC150	1.5	48	47.5	47	46.5	45.5	44.5	43.5	42.5	41.5	41	41.5	39	37	34.5	31	27	22					
ACm150L	1.5	37.5	37.2	37	36.9	36.6	36.2	35.8	35.4	35	34.8	34.7	34	33.3	32.5	31.5	30.5	29.5	28.2	27	24	21	19
AC150L	1.5	37.5	37.2	37	36.9	36.6	36.2	35.8	35.4	35	34.8	34.7	34	33.3	32.5	31.5	30.5	29.5	28.2	27	24	21	19
AC220	2.2	55	54.5	53	53.5	53	52.5	51.5	50.5	49.5	48	48.5	47	45.5	43.5	40	36.5	32.5	28				

Dimensions

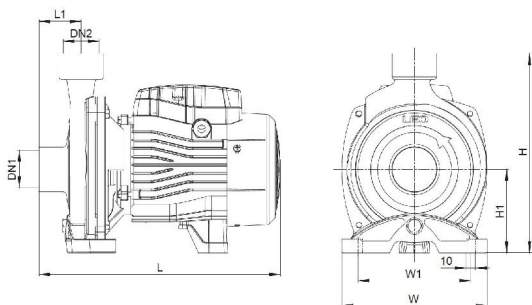

MODEL	DN1	DN2	L	W	H	L1	W1	H1
ACm25	1	1	270	157	216	42	122	90
ACm37	1	1	270	157	216	42	122	90
ACm60	1	1	298	190	240	44	160	90
AC60	1	1	298	190	240	44	160	100
ACm75	1	1	298	190	240	44	160	90
AC75	1	1	298	190	240	44	160	90
ACm110	1½	1	359	206	263	50	178	112
AC110	1½	1	359	206	263	50	178	112
ACm110L	1½	1	356	206	265	48.5	178	112
AC110L	1½	1	356	206	265	48.5	178	112
ACm150	1½	1	360	240	286	51	207	115
AC150	1½	1	360	240	286	51	207	115
ACm150L	1½	1	356	206	265	48.5	178	112
AC150L	1½	1	356	206	265	48.5	178	112
AC220	1½	1	360	240	286	51	207	115

Hydraulic performance

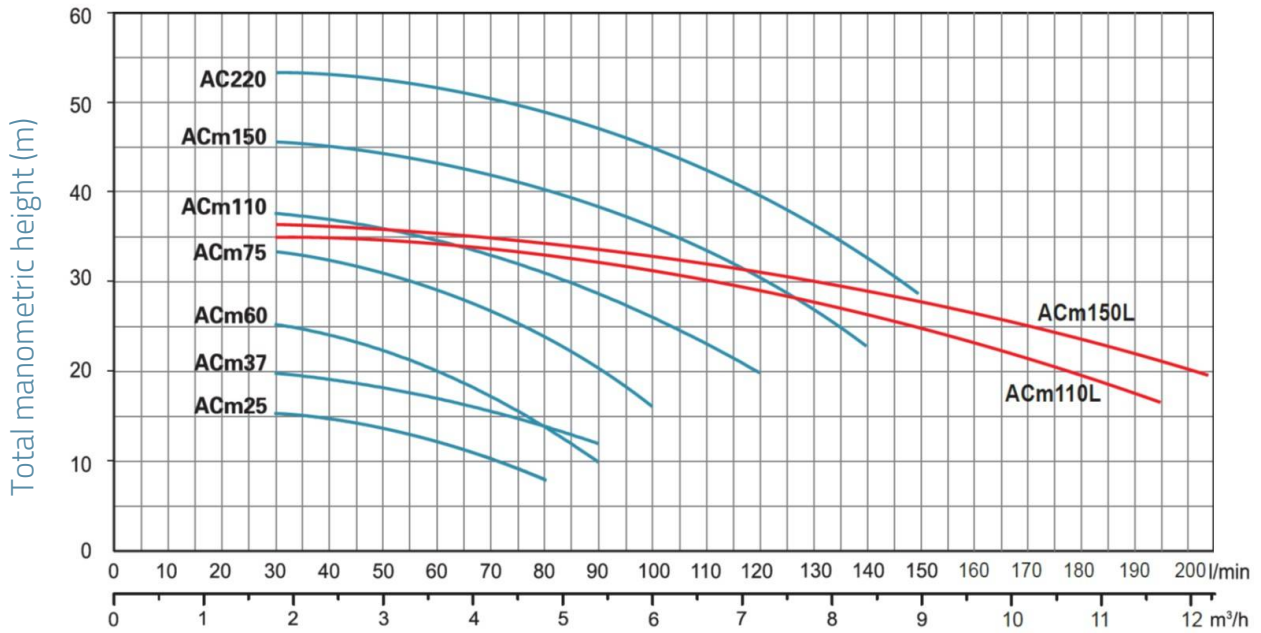

Exploded view

No.	Type	Materials
1	Pump body	cast iron HT200
2	Impeller	AISI 304 stainless steel
3	O-ring	nitrile rubber (NBR)
4	Mechanical seal	carbon / ceramic
5	Pump bottom	stainless steel AISI 304 / cast iron HT200
6	Lantern	cast aluminum ZL102
7	Terminal board	polycarbonate
8	Stator	
9	Electric box cover	ABS
10	Capacitor	
11	Rotor	
12	Bearing	
13	Rear cover	cast aluminum ZL102
14	Fan	polypropylene
15	Fan cover	polypropylene

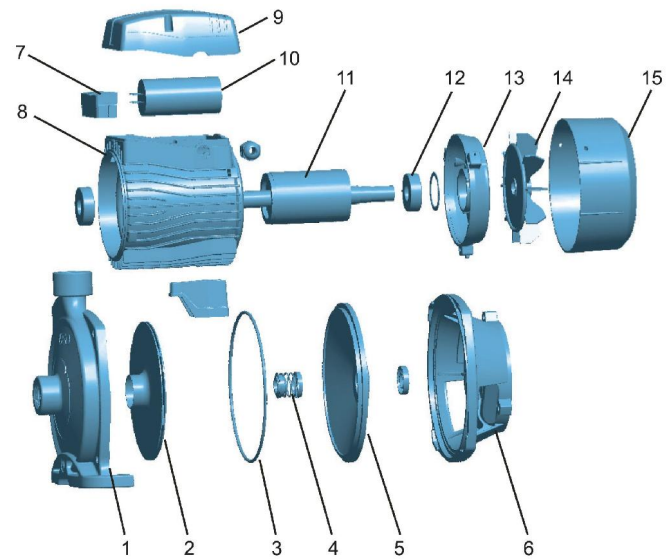

Packaging

MODEL	Weight (kg)	Length L (mm)	Width W (mm)	Height H (mm)
ACm25	7.9	290	185	239
ACm37	8.4	290	185	239
ACm60	11.5	333	215	260
AC60	11.5	333	215	260
ACm75	13.4	333	215	260
AC75	13.4	333	215	260
ACm110	18.45	383	233	287
AC110	18.45	383	233	287
ACm110L	18.4	383	233	287
AC110L	18.4	383	233	287
ACm150	22.8	425	265	310
AC150	22.8	425	265	310
ACm150L	19.35	383	233	287
AC150L	19.35	383	233	287
AC220	23.3	425	265	310

